

JVC

SCHEMATIC DIAGRAMS

COLOUR TELEVISION

AV-14F702

CD-ROM No.SML200111



AV-14F702 STANDARD CIRCUIT DIAGRAM

■ NOTE ON USING CIRCUIT DIAGRAMS

1.SAFETY

The Components identified by the symbol \triangle are critical for safety. For continued safety, replace safety critical components only with manufacturer's recommended parts.

2.INDICATION OF PARTS SYMBOL [EXAMPLE]

●In the PC board :R1209→R209

3.NOTE FOR REPAIRING SERVICE

This model's power circuit is partly different in the GND.

Please, care must be taken for the following points.

(1)Do not touch the LIVE side GND or the LIVE side GND and the ISOLATED(NEUTRAL) side GND simultaneously. If the above caution is not respected, an electric shock may be caused. Therefore, make sure that the power cord is surely removed from the receptacle when, for example, the chassis is pulled out.

(2)Do not short between the LIVE side GND and ISOLATED(NEUTRAL) side GND or never measure with a measuring apparatus (oscilloscope, etc.) the LIVE side GND and ISOLATED(NEUTRAL) side GND at the same time. If the above precaution is not respected , a fuse or any parts will be broken.

◇Since the circuit diagram is a standard one, the circuit and circuit constants may be subject to change for improvement without any notice.

CONTENTS

SEMICONDUCTOR BASE CONNECTIONS	2
BLOCK DIAGRAMS	3
CIRCUIT DIAGRAMS	5
<i>MAIN PCB MICON/TUNER SCHEMATIC DIAGRAM</i>	
<i>MAIN PCB CHROMA/IF SCHEMATIC DIAGRAM</i>	
<i>MAIN PCB DEFLECTION SCHEMATIC DIAGRAM</i>	
<i>MAIN PCB POWER SCHEMATIC DIAGRAM</i>	
<i>MAIN PCB SOUND SCHEMATIC DIAGRAM</i>	
<i>MAIN PCB AV SCHEMATIC DIAGRAM</i>	
<i>COMB FILTER PCB SCHEMATIC DIAGRAM</i>	
<i>CRT/SVM PCB SCHEMATIC DIAGRAM</i>	
PATTERN DIAGRAMS	21
<i>MAIN/ PCB PATTERN</i>	
<i>COMB FILTER PCB PATTERN</i>	
<i>CRT/SVM PCB PATTERN</i>	
WAVEFORMS	27

SEMICONDUCTOR BASE CONNECTIONS

DIODE



1N4937
1SS133T-77
AU02A-EIC
MTZJ11B T-77
MTZJ12B T-77
MTZJ27B T-77
MTZJ33B T-77
MTZJ5.1B T-77
MTZJ5.6B T-77
MTZJ6.2B T-77
MTZJ9.1B T-77
RS-4FS



11E1-EIC
30DF6-FC
RU2YX-V1



RM11C-EIC
RU-4AM
SB290S

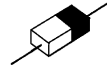

1SS355 TE-17



SLR-342VCT32

IC

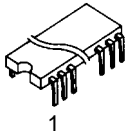

OEC7055B
TB1253N

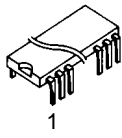

M62420SP
MM1311AD

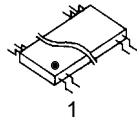

AN5829S

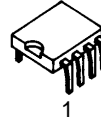

S-24C08ADPA-01

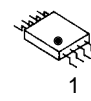

NJM2150AM

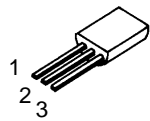

PST600C

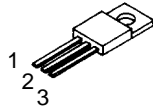

KIA7805API
KIA7809API

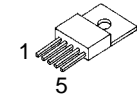

STR-G6623

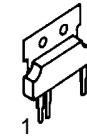

AN5276

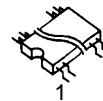

TC90A45F

TRANSISTOR

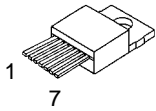

AN5522

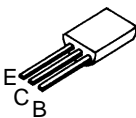

2SA1015Y(TPE2)
2SA1624E-AA
2SC1815Y(TPE2)
2SD734(E,F)-AA

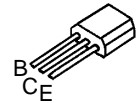

2SC1740SP(R,S) TP
KTA1273_Y

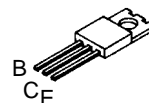

2SC4159(D,E)

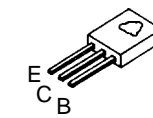

2SC2621(D,E)-RAC

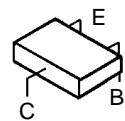

2SA1037AKT146R,S
2SC2412KT146 R,S
2SC2814(F3,F4)-T
KRA102SRTK
KRA104RTK
KRC102RTK
KRC111RTK

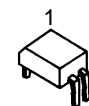

LTV-817M-VB

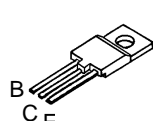

2SD2499(LB0EC1)

BLOCK DIAGRAM

- ◀ DEFLECTION SIGNAL
- ↔ AUDIO SIGNAL
- ▶ TUNER AUDIO SIGNAL
- ▲ G. SIGNAL
- ▬ COLOR SIGNAL
- ▬ LUMINANCE SIGNAL
- ▶ TUNER VIDEO SIGNAL
- ▲ B. SIGNAL
- ▶ R. SIGNAL

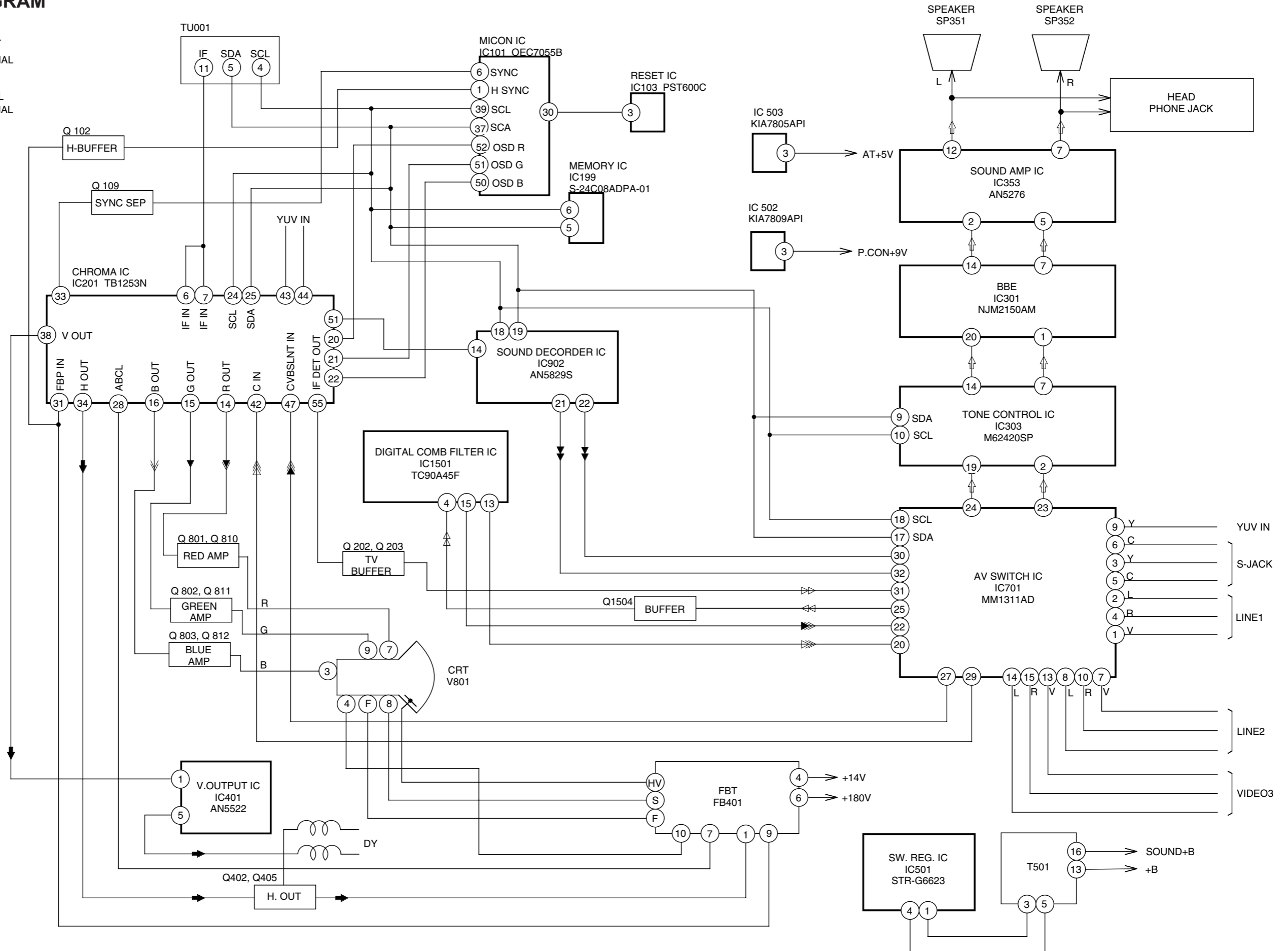

CIRCUIT DIAGRAM [MAIN PCB MICON/TUNER SCHEMATIC DIAGRAM]

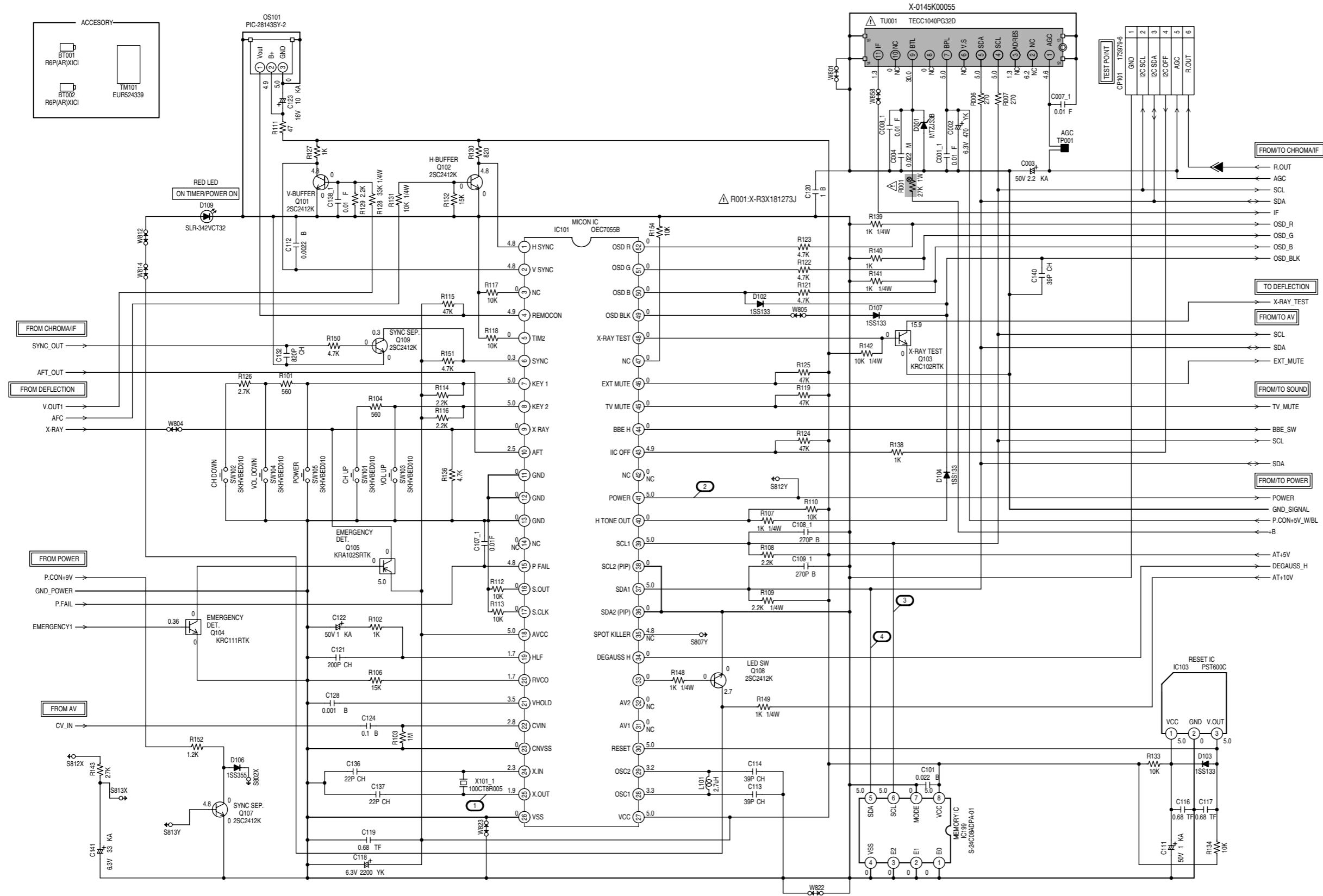

NOTE: THE DC VOLTAGE AT EACH PART WAS MEASURED WITH THE DIGITAL TESTER WHEN THE COLOR BROADCAST WAS RECEIVED IN GOOD CONDITION AND PICTURE IS NORMAL.

NOTE: THIS SCHEMATIC DIAGRAM IS THE LATEST AT THE TIME OF PRINTING AND SUBJECT TO CHANGE WITHOUT NOTICE.

CAUTION: SINCE THESE PARTS MARKED BY ARE CRITICAL FOR SAFETY, USE ONES DESCRIBED IN PARTS LIST ONLY.

ATTENTION: LES PIÈCES RÉPARÉES PAR UN ÉTANT DANGEREUSES AN POINT DE VUE SÉCURITÉ N'UTILISER QUE CELLES DÉCRITES DANS LA NOMENCLATURE DES PIÈCES.

CAUTION: DIGITAL TRANSISTOR

CAUTION: DIGITAL TRANSISTOR

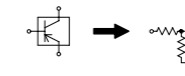
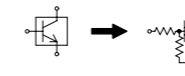

R.SIGNAL

【 MAIN PCB CHROMA/IF SCHEMATIC DIAGRAM 】

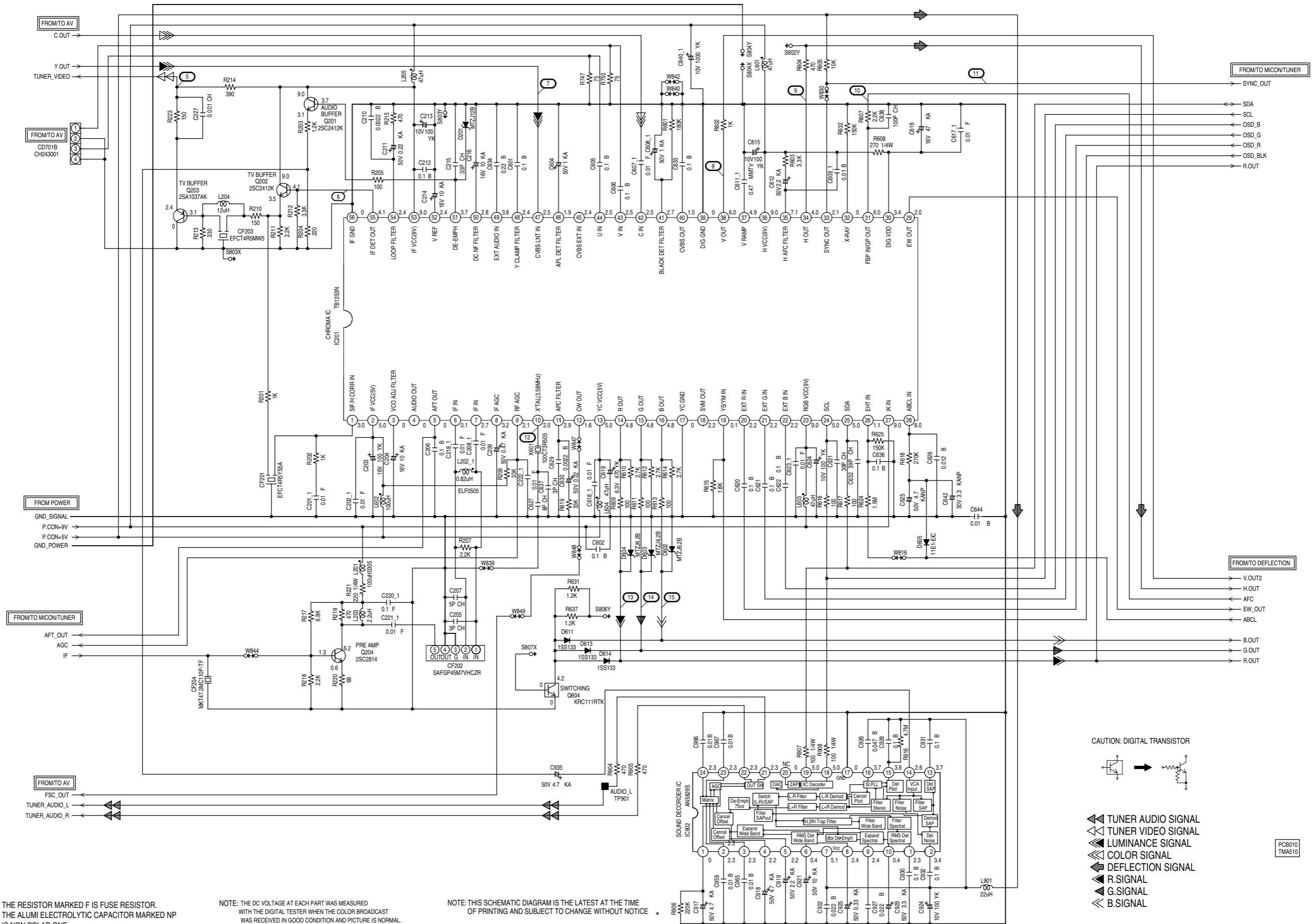

NOTE: THE RESISTOR MARKED F IS FUSE RESISTOR.
THE ALUMI ELECTROLYTIC CAPACITOR MARKED NP IS NON POLAR ONE.

NOTE: THE DC VOLTAGE AT EACH PART WAS MEASURED WITH THE DIGITAL TESTER WHEN THE COLOR BROADCAST WAS RECEIVED IN GOOD CONDITION AND PICTURE IS NORMAL.

NOTE: THIS SCHEMATIC DIAGRAM IS THE LATEST AT THE TIME OF PRINTING AND SUBJECT TO CHANGE WITHOUT NOTICE.

CAUTION: DIGITAL TRANSISTOR

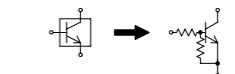

- ▶ TUNER AUDIO SIGNAL
- ▶ TUNER VIDEO SIGNAL
- ▶ LUMINANCE SIGNAL
- ▶ COLOR SIGNAL
- ▶ DEFLECTION SIGNAL
- ▶ R.SIGNAL
- ▶ G.SIGNAL
- ▶ B.SIGNAL

PCB010
TMA510

【 MAIN PCB DEF DIAGRAM 】

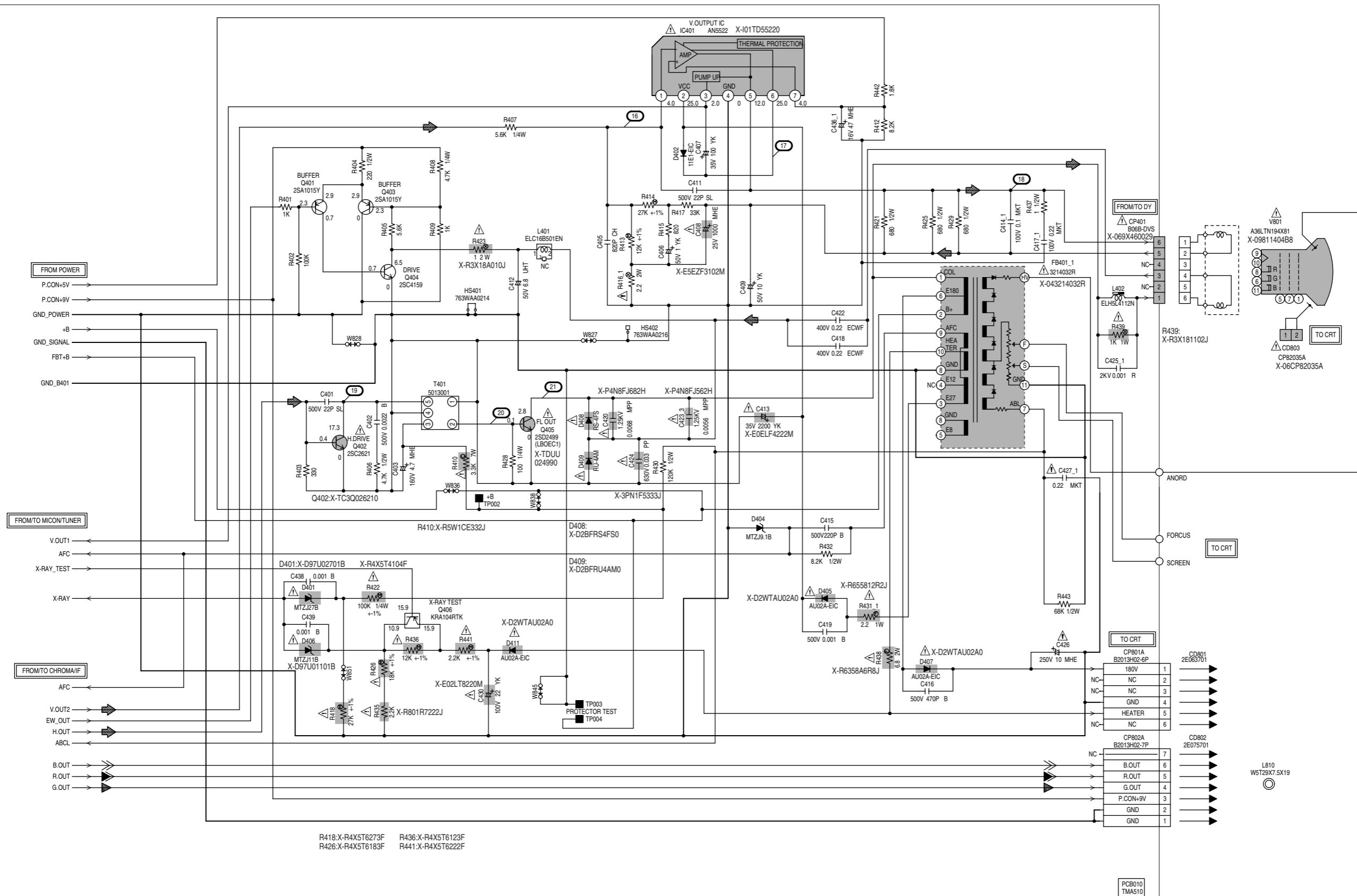

NOTE: THE DC VOLTAGE AT EACH PART WAS MEASURED WITH THE DIGITAL TESTER WHEN THE COLOR BROADCAST WAS RECEIVED IN GOOD CONDITION AND PICTURE IS NORMAL.

NOTE: THIS SCHEMATIC DIAGRAM IS THE LATEST AT THE TIME OF PRINTING AND SUBJECT TO CHANGE WITHOUT NOTICE.

CAUTION: SINCE THESE PARTS MARKED BY ARE CRITICAL FOR SAFETY, USE ONES DESCRIBED IN PARTS LIST ONLY.

ATTENTION: LES PIECES REPARÉES PAR UN ÉTANT DANGEREUSES AN POINT DE VUE SECURITE NUTILISER QUE CELLS DECRITES DANS LA NOMENCLATURE DES PIECES.

NOTE: THE RESISTOR MARKED F IS FUSE RESISTOR. THE ALUMI ELECTROLYTIC CAPACITOR MARKED NP IS NON POLAR ONE.

CAUTION: DIGITAL TRANSISTOR

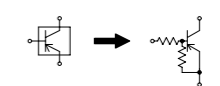

DEFLECTION SIGNAL
 R.SIGNAL
 G.SIGNAL
 B.SIGNAL

【 MAIN PCB POWER CIRCUIT DIAGRAM 】



CAUTION: FOR CONTINUED PROTECTION AGAINST FIRE HAZARD, REPLACE ONLY WITH THE SAME TYPE FUSE 6.3A 125V(F501)

ATTENTION: POUR UNE PROTECTION CONTINUE LES RISQUES D'INCEIE N'UTILISER QUE DES FUSIBLE DE MEME TYPE 6.3A 125V(F501)

CAUTION: ICP501 IS MANUFACTURED BY LITTELFUSE INC.,TYPE 251.

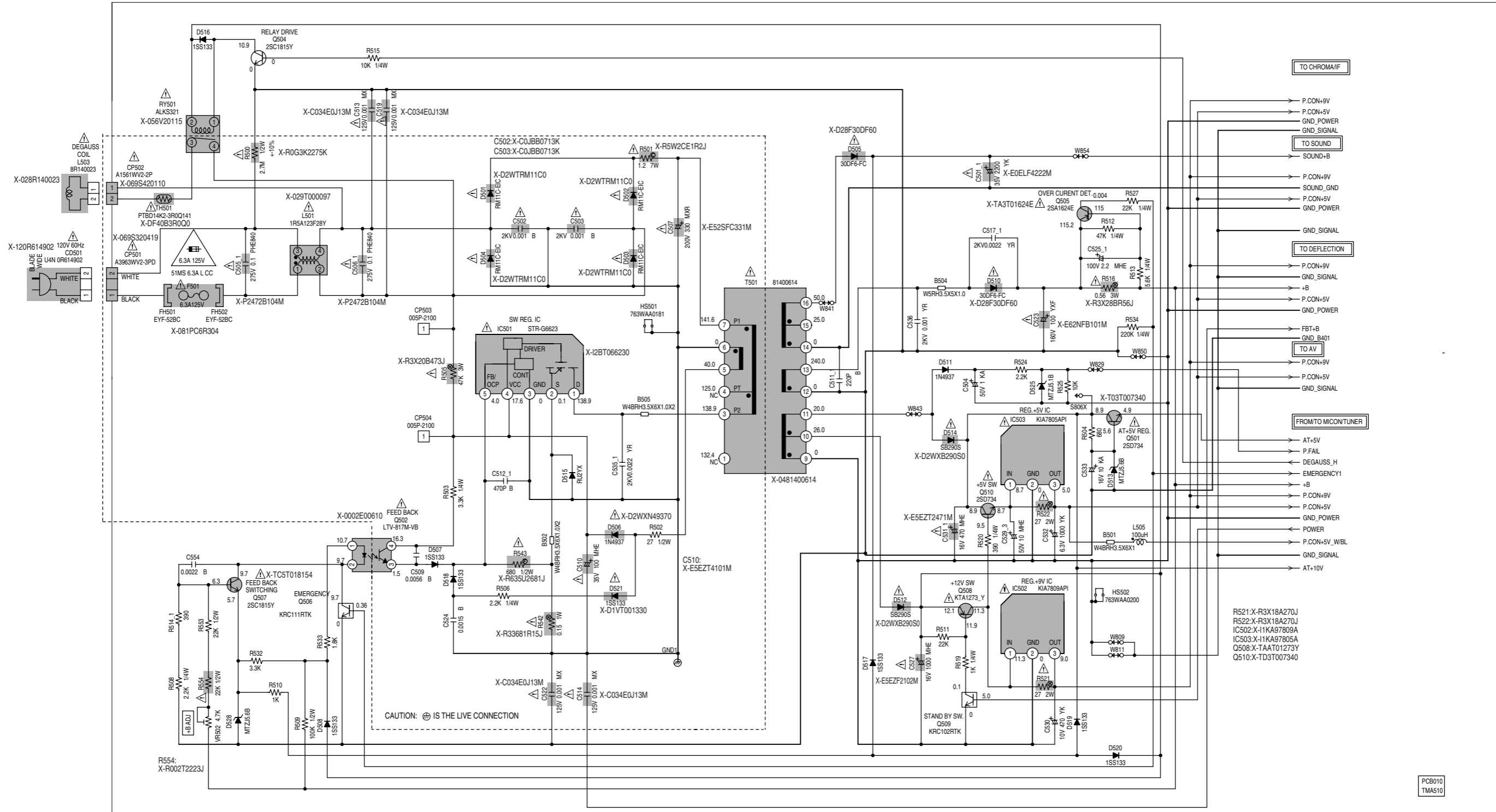

NOTE: THE DC VOLTAGE AT EACH PART WAS MEASURED WITH THE DIGITAL TESTER WHEN THE COLOR BROADCAST WAS RECEIVED IN GOOD CONDITION AND PICTURE IS NORMAL.

NOTE: THIS SCHEMATIC DIAGRAM IS THE LATEST AT THE TIME OF PRINTING AND SUBJECT TO CHANGE WITHOUT NOTICE.

CAUTION: SINCE THESE PARTS MARKED BY ARE CRITICAL FOR SAFETY, USE ONES DESCRIBED IN PARTS LIST ONLY.

ATTENTION: LES PIECES REPARÉES PAR UN ETANT DANGEREUSES AN POINT DE VUE SECURITE N'UTILISER QUE CELLS DECRITES DANS LA NOMENCLATURE DES PIECES.

NOTE: THE RESISTOR MARKED F IS FUSE RESISTOR. THE ALUMI ELECTROLYTIC CAPACITOR MARKED NP IS NON POLAR ONE.

CAUTION: DIGITAL TRANSISTOR

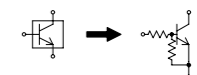

【 MAIN PCB SOUND CIRCUIT DIAGRAM 】

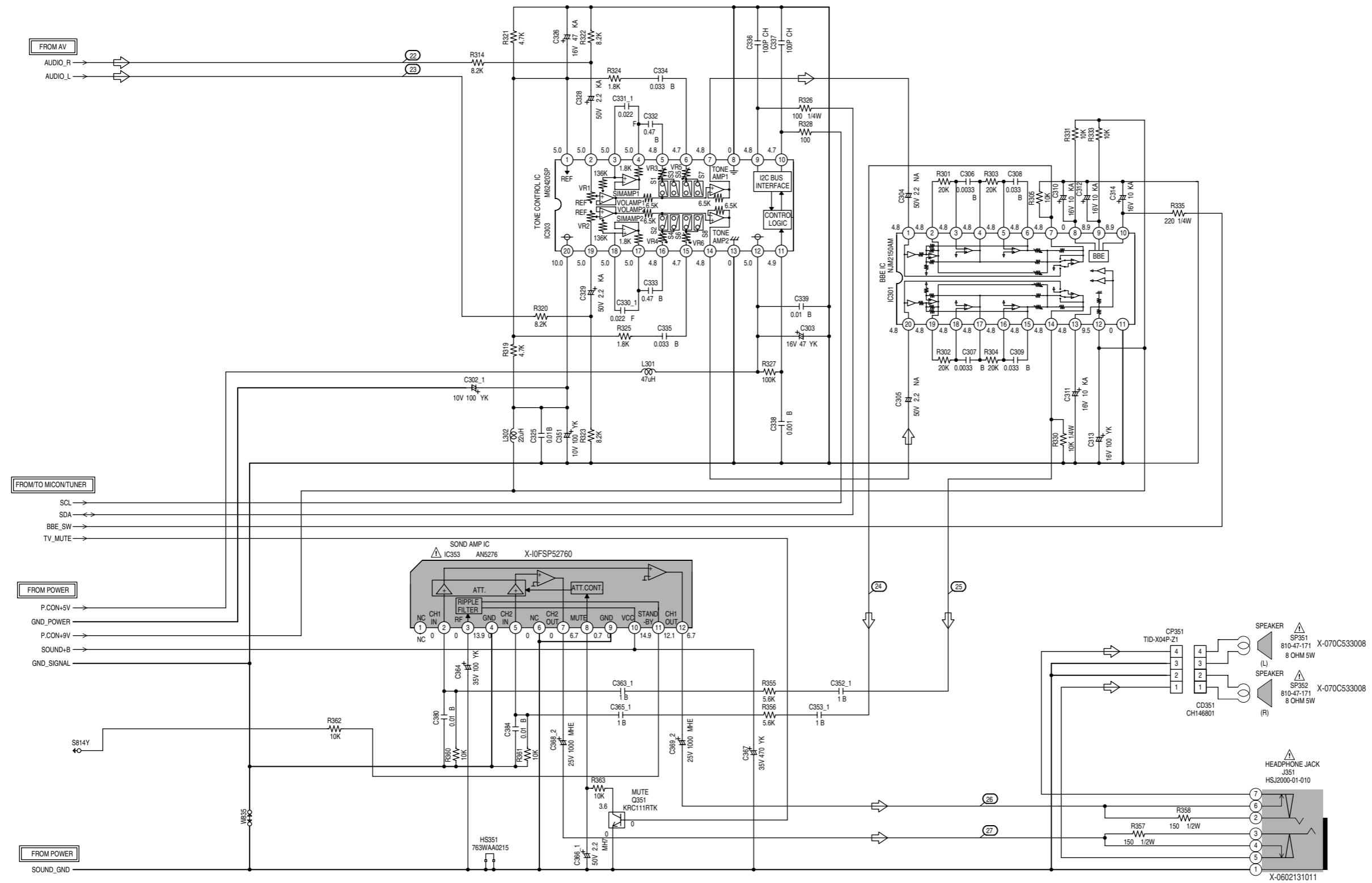

NOTE: THE DC VOLTAGE AT EACH PART WAS MEASURED WITH THE DIGITAL TESTER WHEN THE COLOR BROADCAST WAS RECEIVED IN GOOD CONDITION AND PICTURE IS NORMAL.

NOTE: THIS SCHEMATIC DIAGRAM IS THE LATEST AT THE TIME OF PRINTING AND SUBJECT TO CHANGE WITHOUT NOTICE.

CAUTION: SINCE THESE PARTS MARKED BY ARE CRITICAL FOR SAFETY, USE ONES DESCRIBED IN PARTS LIST ONLY.

ATTENTION: LES PIECES REPAREES PAR UN ETANT DANGEREUSES AN POINT DE VUE SECURITE NUTILISER QUE CELLS DECRITES DANS LA NOMENCLATURE DES PIECES.

NOTE: THE RESISTOR MARKED F IS FUSE RESISTOR. THE ALUMI ELECTROLYTIC CAPACITOR MARKED NP IS NON POLAR ONE.

AUDIO SIGNAL

PCB010 TMA510

CAUTION: DIGITAL TRANSISTOR

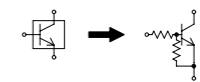

【 MAIN PCB AV CIRCUIT DIAGRAM 】

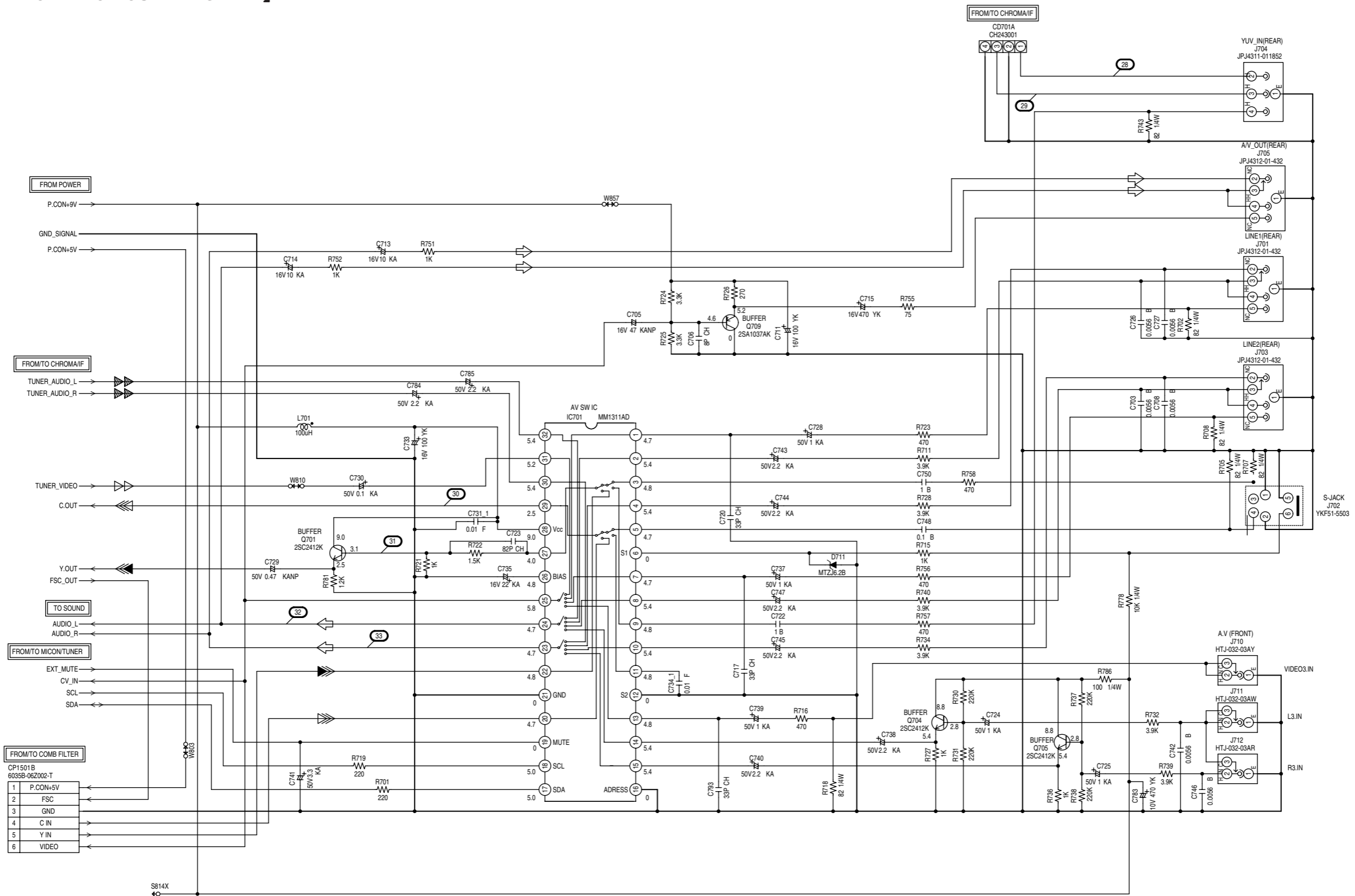

NOTE: THE RESISTOR MARKED F IS FUSE RESISTOR.
THE ALUMI ELECTROLYTIC CAPACITOR MARKED NP IS NON POLAR ONE.

NOTE: THE DC VOLTAGE AT EACH PART WAS MEASURED WITH THE DIGITAL TESTER WHEN THE COLOR BROADCAST WAS RECEIVED IN GOOD CONDITION AND PICTURE IS NORMAL.

NOTE: THIS SCHEMATIC DIAGRAM IS THE LATEST AT THE TIME OF PRINTING AND SUBJECT TO CHANGE WITHOUT NOTICE.

CAUTION: DIGITAL TRANSISTOR

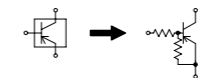

- ◁ AUDIO SIGNAL
- ▷ TUNER AUDIO SIGNAL
- ▷ TUNER VIDEO SIGNAL
- ▷ COLOR SIGNAL
- ▷ LUMINANCE SIGNAL

PCB010 TMA510

【 CRT/VM PCB CIRCUIT DIAGRAM 】

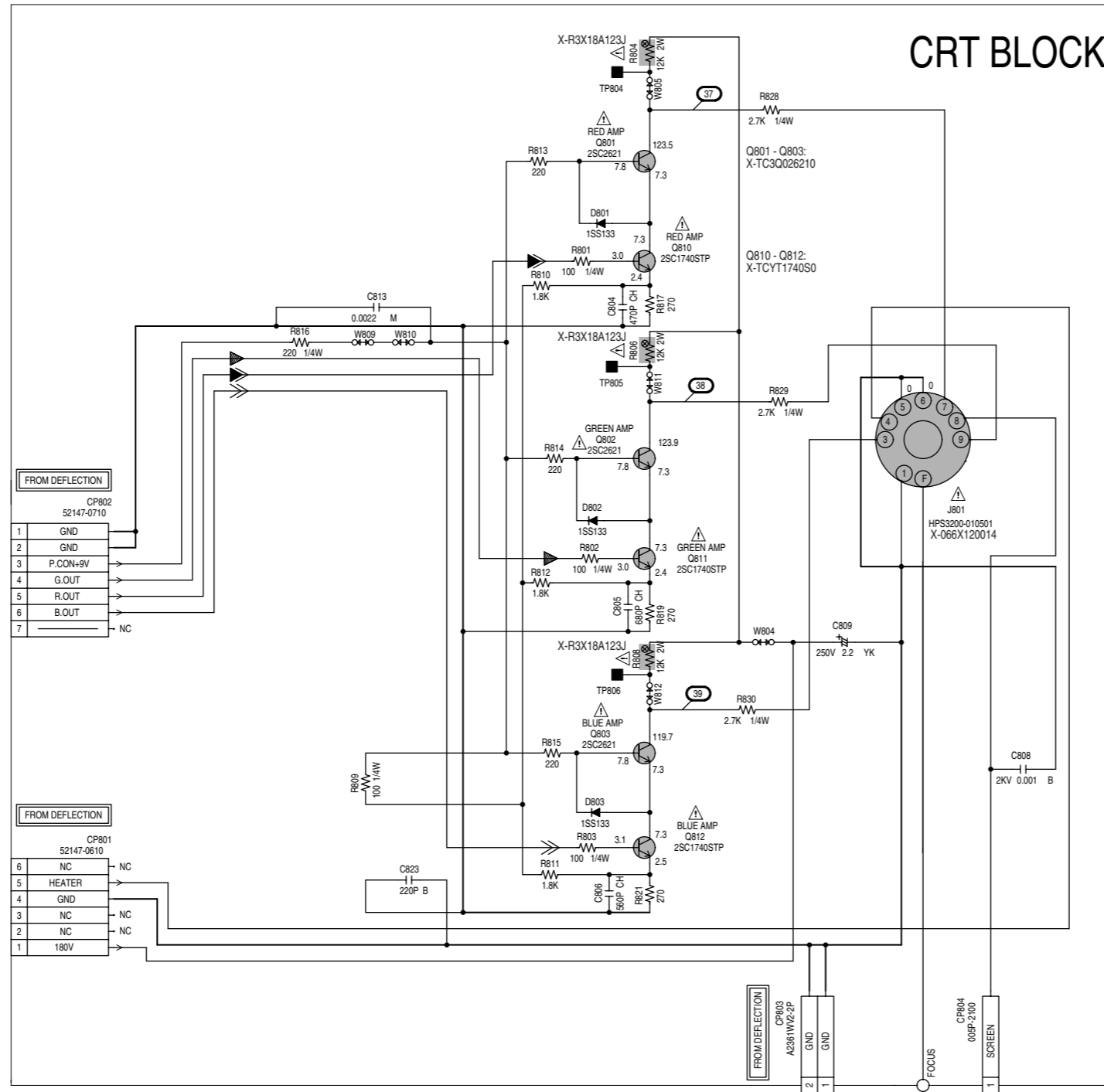

NOTE: THE DC VOLTAGE AT EACH PART WAS MEASURED WITH THE DIGITAL TESTER WHEN THE COLOR BROADCAST WAS RECEIVED IN GOOD CONDITION AND PICTURE IS NORMAL.

NOTE: THIS SCHEMATIC DIAGRAM IS THE LATEST AT THE TIME OF PRINTING AND SUBJECT TO CHANGE WITHOUT NOTICE .

CAUTION: SINCE THESE PARTS MARKED BY ARE CRITICAL FOR SAFETY, USE ONES DESCRIBED IN PARTS LIST ONLY .

ATTENTION: LES PIECES REPARÉES PAR UN ETANT DANGEREUSES AN POINT DE VUE SECURITE N'UTILISER QUE CELLS DECRITES DANS LA NOMENCLATURE DES PIECES .

R.SIGNAL
 G.SIGNAL
 B.SIGNAL

PCB110
TCA365

【 COMB PCB CIRCUIT DIAGRAM 】

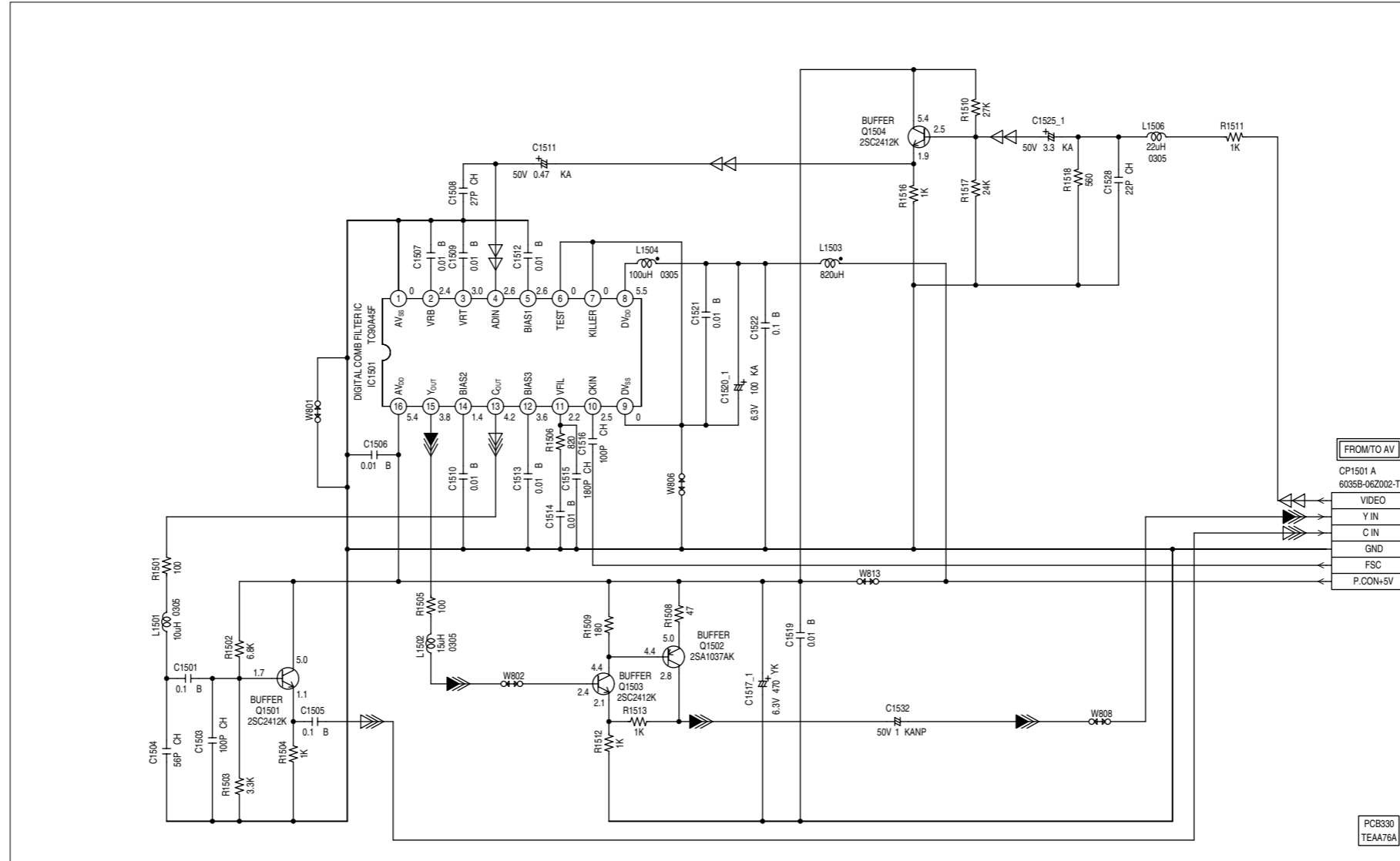

NOTE: THIS SCHEMATIC DIAGRAM IS THE LATEST AT THE TIME OF PRINTING AND SUBJECT TO CHANGE WITHOUT NOTICE .

NOTE: THE DC VOLTAGE AT EACH PART WAS MEASURED WITH THE DIGITAL TESTER WHEN THE COLOR BROADCAST WAS RECEIVED IN GOOD CONDITION AND PICTURE IS NORMAL.

- ◀◀ RECORD COLOR SIGNAL
- ◀ RECORD LUMINANCE SIGNAL
- ◀◀ TUNER VIDEO SIGNAL

PATTERN DIAGRAM

[MAIN PCB PATTERN (INSERTED PARTS)]

PRINTED CIRCUIT BOARDS
MAIN (INSERTED PARTS)
SOLDER SIDE

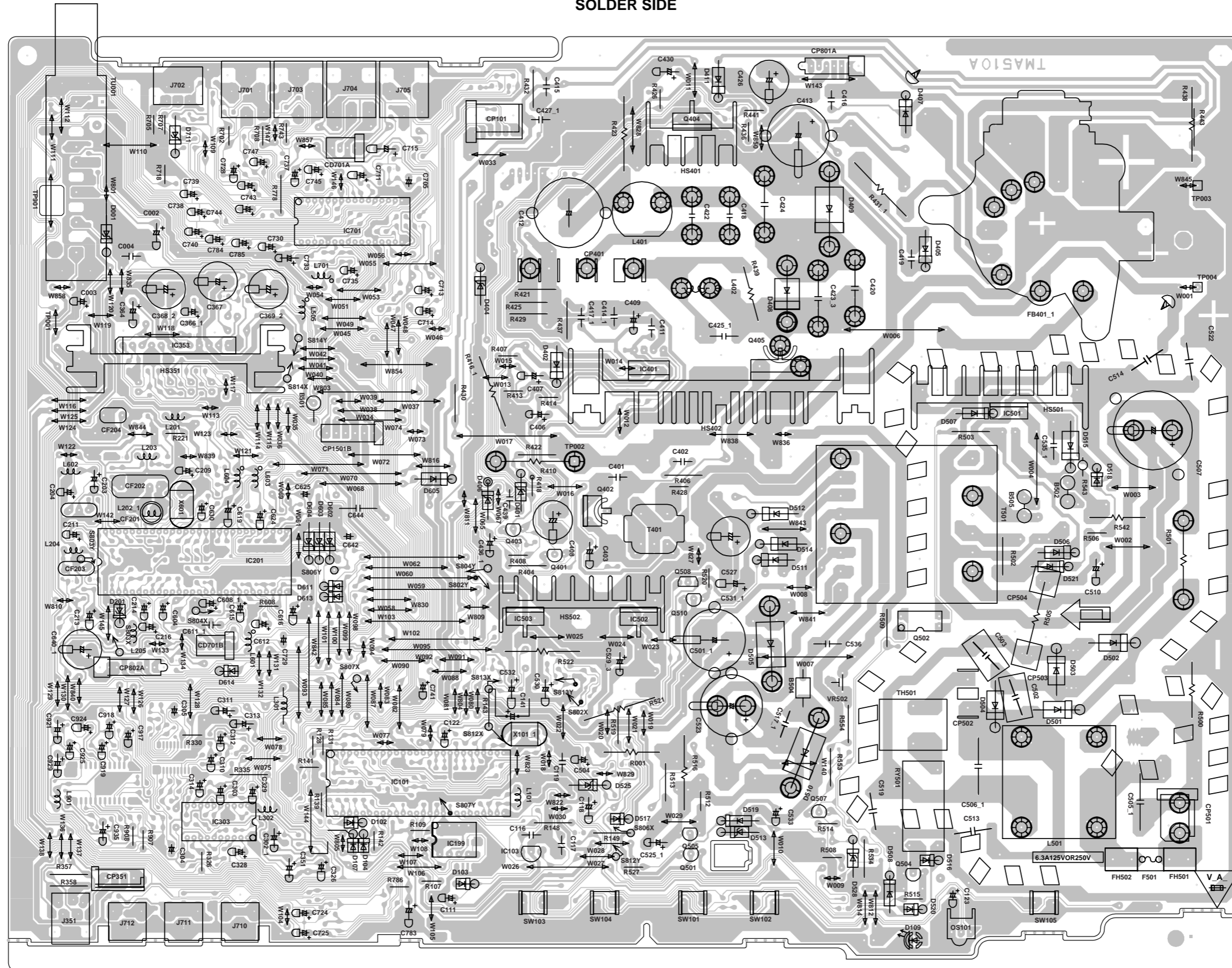

【 MAIN PCB PATTERN (CHIP MOUNTED PARTS) 】

PRINTED CIRCUIT BOARDS
MAIN (CHIP MOUNTED PARTS)
SOLDER SIDE

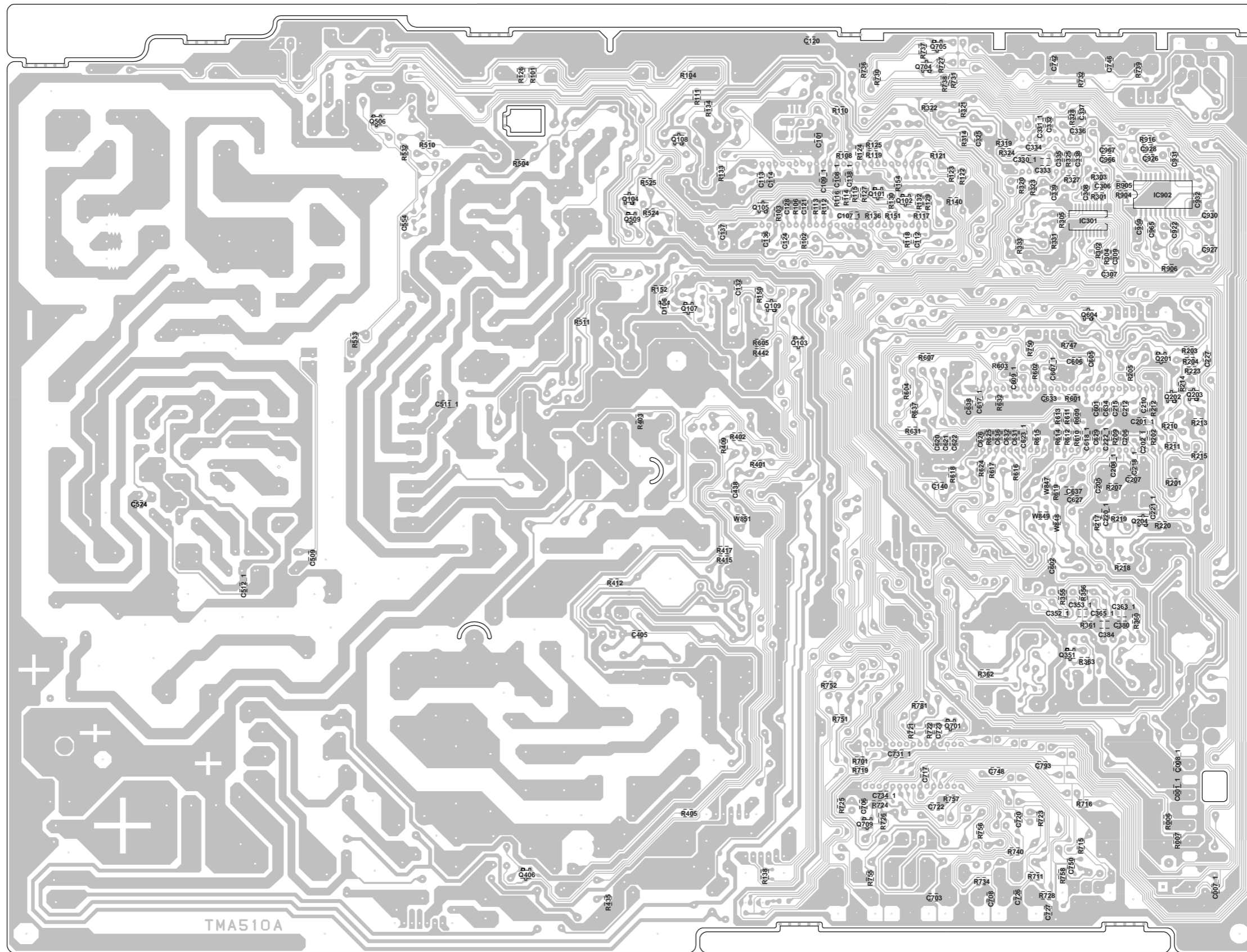

[COMB FILTER PCB PATTERN]

[CRT/VM PCB PATTERN]

**COMB (INSERTED PARTS)
SOLDER SIDE**

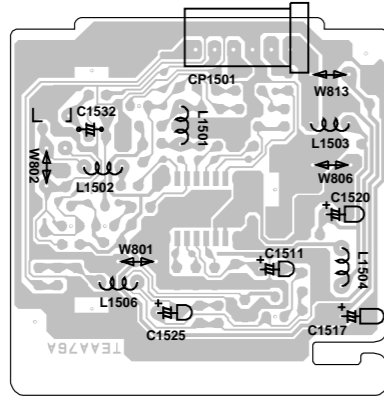

**COMB (CHIP MOUNTED PARTS)
SOLDER SIDE**

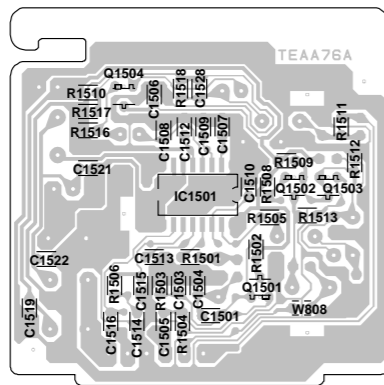

**CRT
SOLDER SIDE**

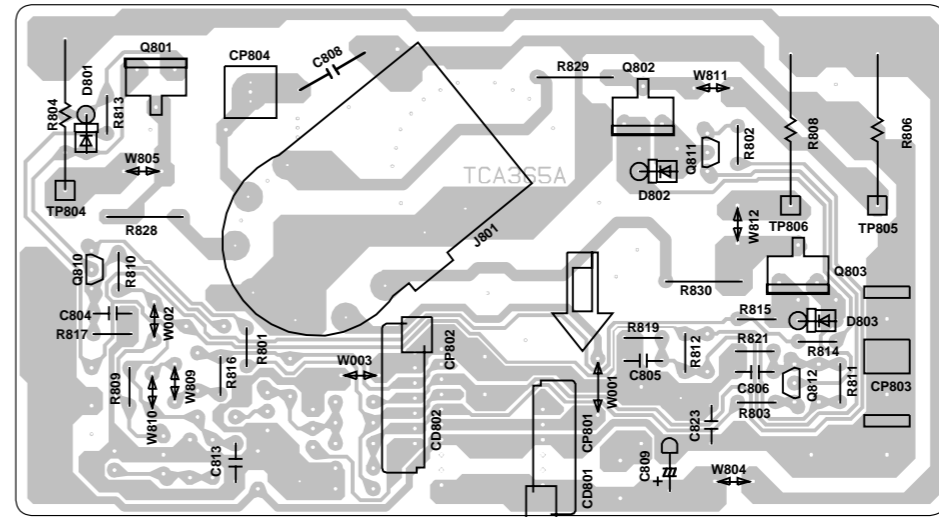

WAVEFORMS

MICON/TUNER

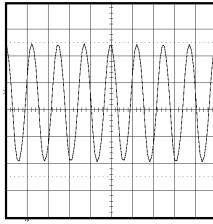

① 1V 0.1μs/div

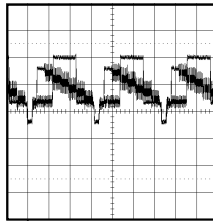

⑥ 1V 20μs/div

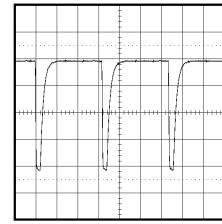

⑪ 0.5V 20μs/div

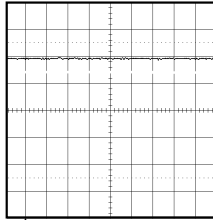

② 1V 1μs/div

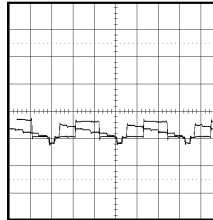

⑦ 1V 20μs/div

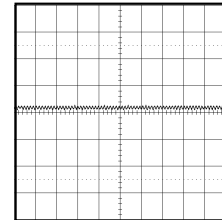

⑫ 1V 2μs/div

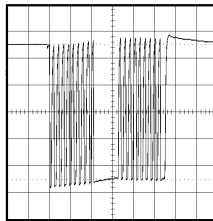

③ 1V 50μs/div

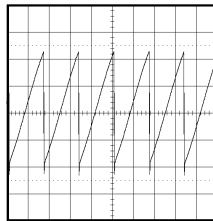

⑧ 0.5V 10ms/div

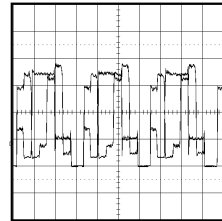

⑬ 1V 20μs/div

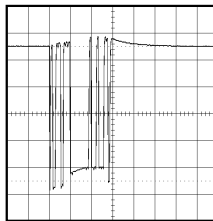

④ 1V 0.1ms/div

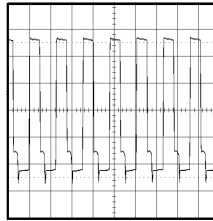

⑨ 1V 50μs/div

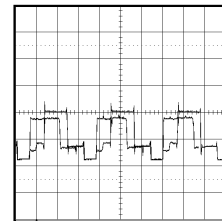

⑭ 2V 20μs/div

CHROMA/IF

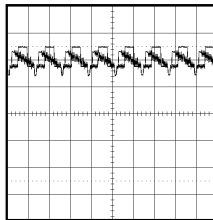

⑤ 1V 50μs/div

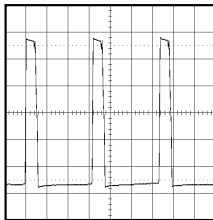

⑩ 2V 20μs/div

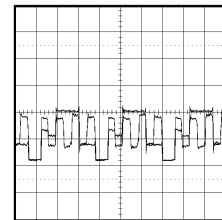

⑮ 2V 20μs/div

NOTE: The following waveforms were measured at the point of the corresponding balloon number in the schematic diagram.

DEFLECTION

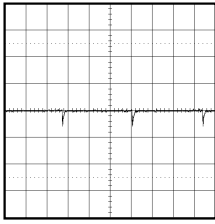

①⑥ 2V 5ms/div

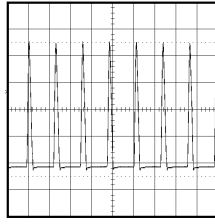

②① 200V 50μs/div

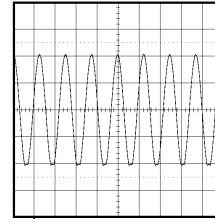

②⑥ 5V 2ms/div

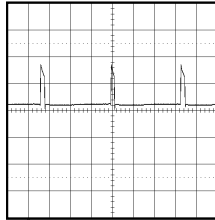

①⑦ 20V 5ms/div

SOUND

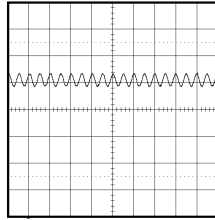

②② 2V 5ms/div

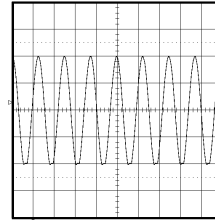

②⑦ 5V 2ms/div

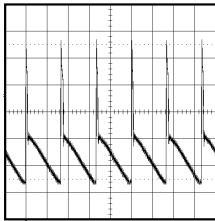

①⑧ 10V 10ms/div

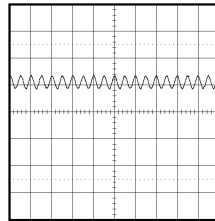

②③ 2V 5ms/div

AV

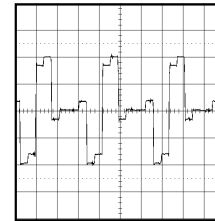

②⑧ 200mV 20μs/div

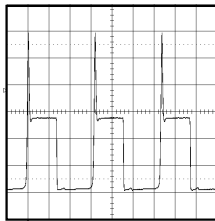

①⑨ 20V 20μs/div

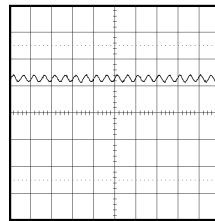

②④ 2V 5ms/div

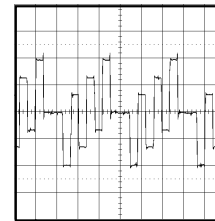

②⑨ 200mV 20μs/div

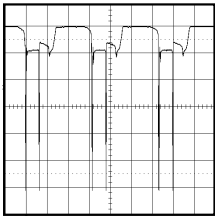

②⑩ 2V 20μs/div

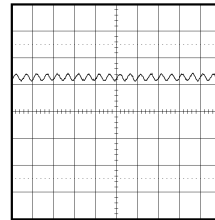

②⑤ 2V 5ms/div

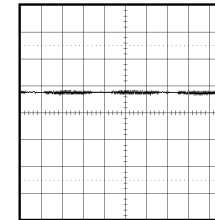

③⑩ 2V 20μs/div

NOTE: The following waveforms were measured at the point of the corresponding balloon number in the schematic diagram.

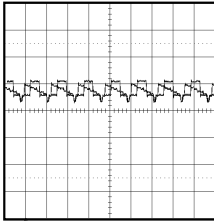

31 1V 50μs/div

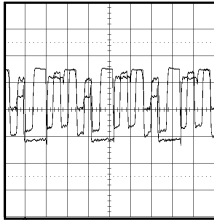

39 50V 20μs/div

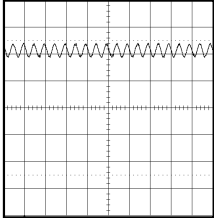

32 2V 5ms/div

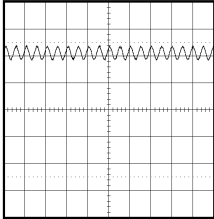

33 2V 5ms/div

CRT

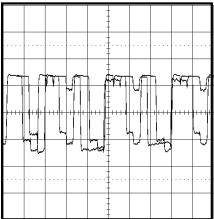

37 50V 20μs/div

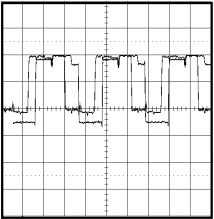

38 50V 20μs/div

NOTE: The following waveforms were measured at the point of the corresponding balloon number in the schematic diagram.

JVC SERVICE & ENGINEERING COMPANY OF AMERICA
DIVISION OF JVC AMERICAS CORP.

Head office :	1700 Valley Road, Wayne, New Jersey 07470	(973)317-5000
East Coast :	10 New Maple Avenue, Pine Brook, New Jersey 07058	(973)396-1000
Midwest :	705 Enterprise St. Aurora, Illinois 60504	(630)851-7855
West Coast:	5665 Corporate Avenue, Cypress, California 90630	(714)229-8011
Southwest :	10700 Hammerly, Suite 105, Houston, Texas 77043	(713)935-9331
Hawaii :	2969 Mapunapuna Place, Honolulu, Hawaii 96819	(808)833-5828
Southeast :	1500 Lakes Parkway, Lawrenceville, Georgia 30243	(770)339-2582

JVC CANADA INC.

Head office :	21 Finchdene Square Scarborough, Ontario M1X 1A7	(416)293-1311
Vancouver :	13040 Worster Court Richmond B.C. V6V 2B3	(604)270-1311

JVC